

HQ:XSC11/Al BS

AFM Probe with 4 Different Cantilevers for Various Applications

AFM probes of the HQ:XSC11 series have four different AFM cantilevers, two on each side of the holder chip. They can be used in various applications.

The HQ AFM probes offer high consistency of the AFM tip radius, the AFM cantilever reflectivity and the quality factor.

The aluminum reflective coating enhances the laser reflectivity of the AFM cantilevers by approximately 2.5 times. For operation in liquids we recommend using the HQ:NSC36/Cr-Au BS with a reflective gold coating.

Coating

Reflective Aluminum

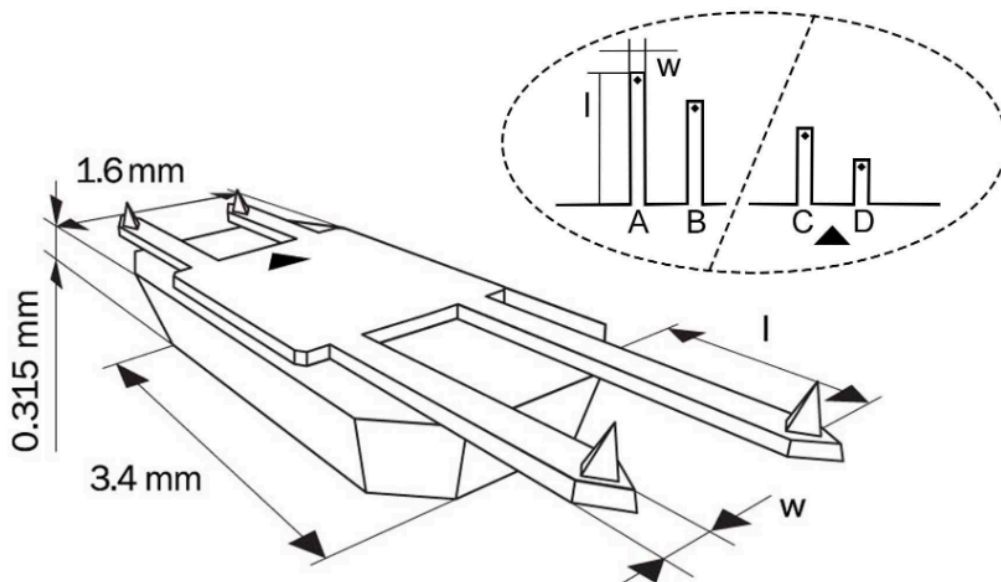

AFM Probe Specifications

AFM Tip

SHAPE	HEIGHT	FULL CONE ANGLE	RADIUS
Rotated	15 μm (12 – 18 μm)*	40°	< 8 nm

AFM Cantilever

CANTILEVER	SHAPE	FORCE CONST.	RES. FREQ.	LENGTH	WIDTH	THICKNESS
Cantilever A	Beam	0.2 N/m (0.1 – 0.4 N/m)*	15 kHz (12 – 18 kHz)*	500 μm (1 – 505 μm)*	30 μm (27 – 33 μm)*	2.7 μm (2.2 – 3.2 μm)*
Cantilever B	Beam	2.7 N/m (1.1 – 5.6 N/m)*	80 kHz (60 – 100 kHz)*	210 μm (1 – 215 μm)*	30 μm (27 – 33 μm)*	2.7 μm (2.2 – 3.2 μm)*
Cantilever C	Beam	7 N/m (3 – 16 N/m)*	155 kHz (115 – 200 kHz)*	150 μm (1 – 155 μm)*	30 μm (27 – 33 μm)*	2.7 μm (2.2 – 3.2 μm)*
Cantilever D	Beam	42 N/m (17 – 90 N/m)*	350 kHz (250 – 465 kHz)*	100 μm (1 – 105 μm)*	50 μm (47 – 53 μm)*	2.7 μm (2.2 – 3.2 μm)*

* typical values